

**Connection between RF and Baseband modules** (Version 0391 Edit 2) for layout version 14

RF

BASEBAND

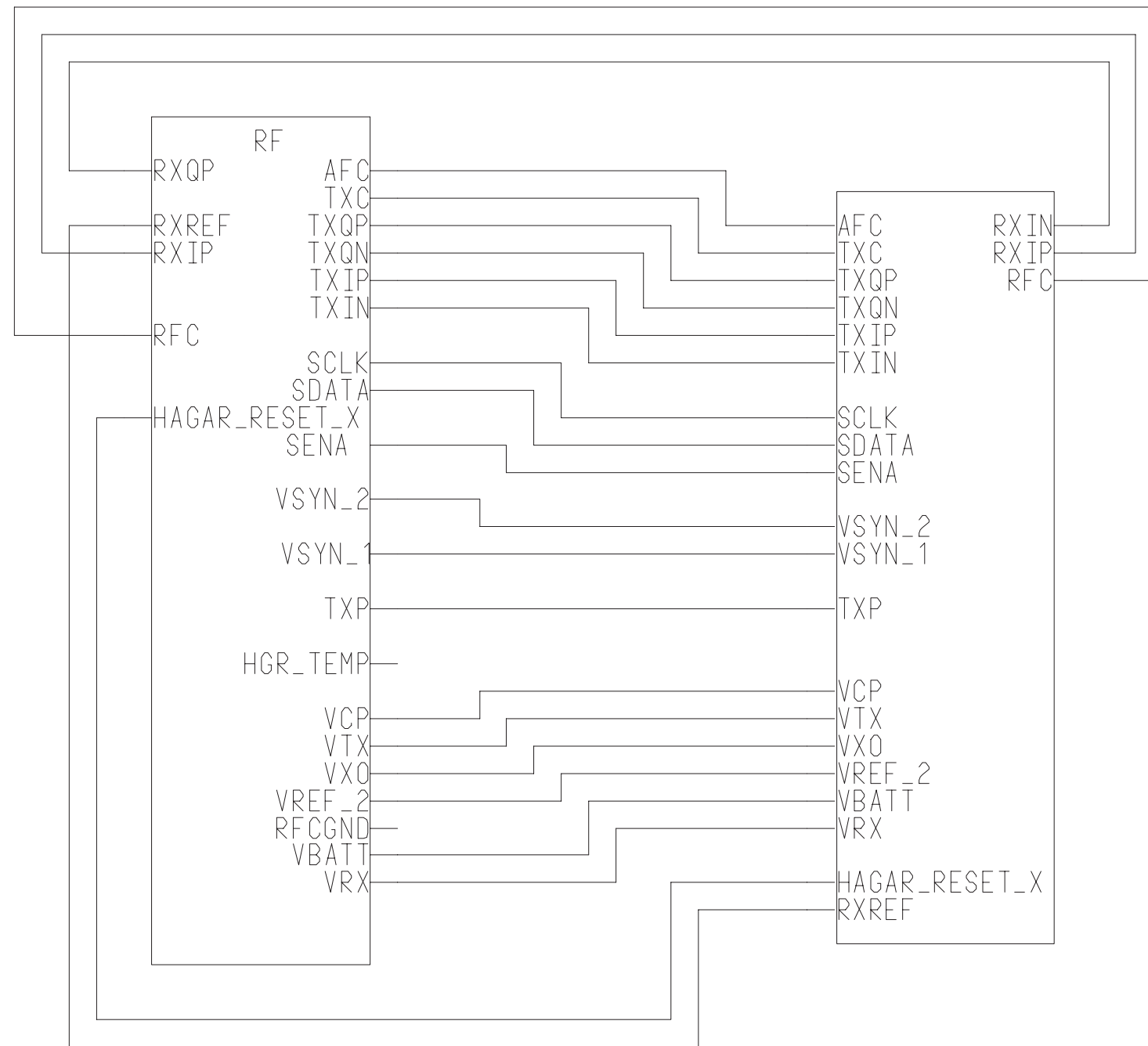

**Baseband Block Interconnections** (Version 0391 Edit 2) for layout version 14

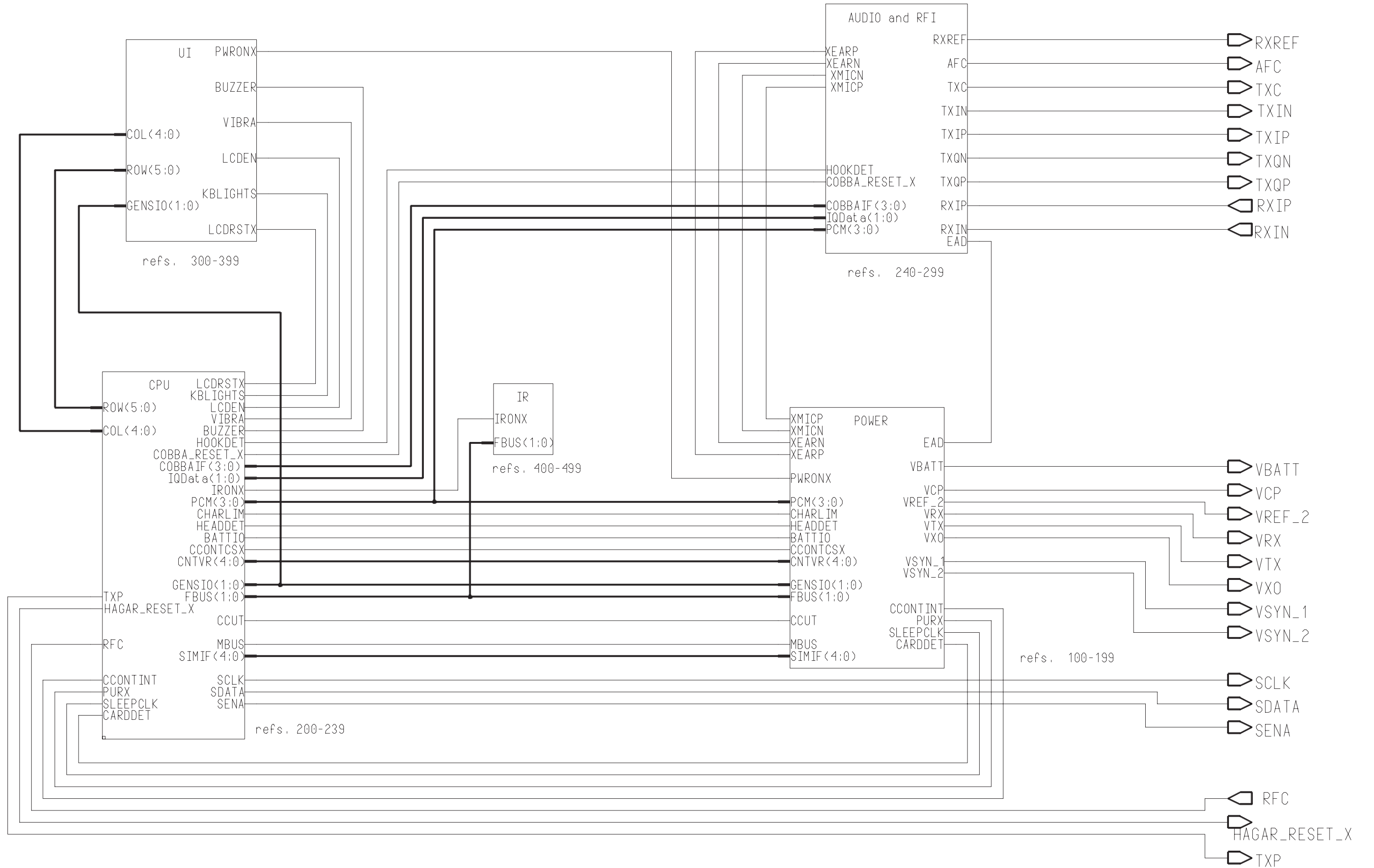



**Circuit Diagram of CPU Block** (Version 0391 Edit 2) for layout version 14

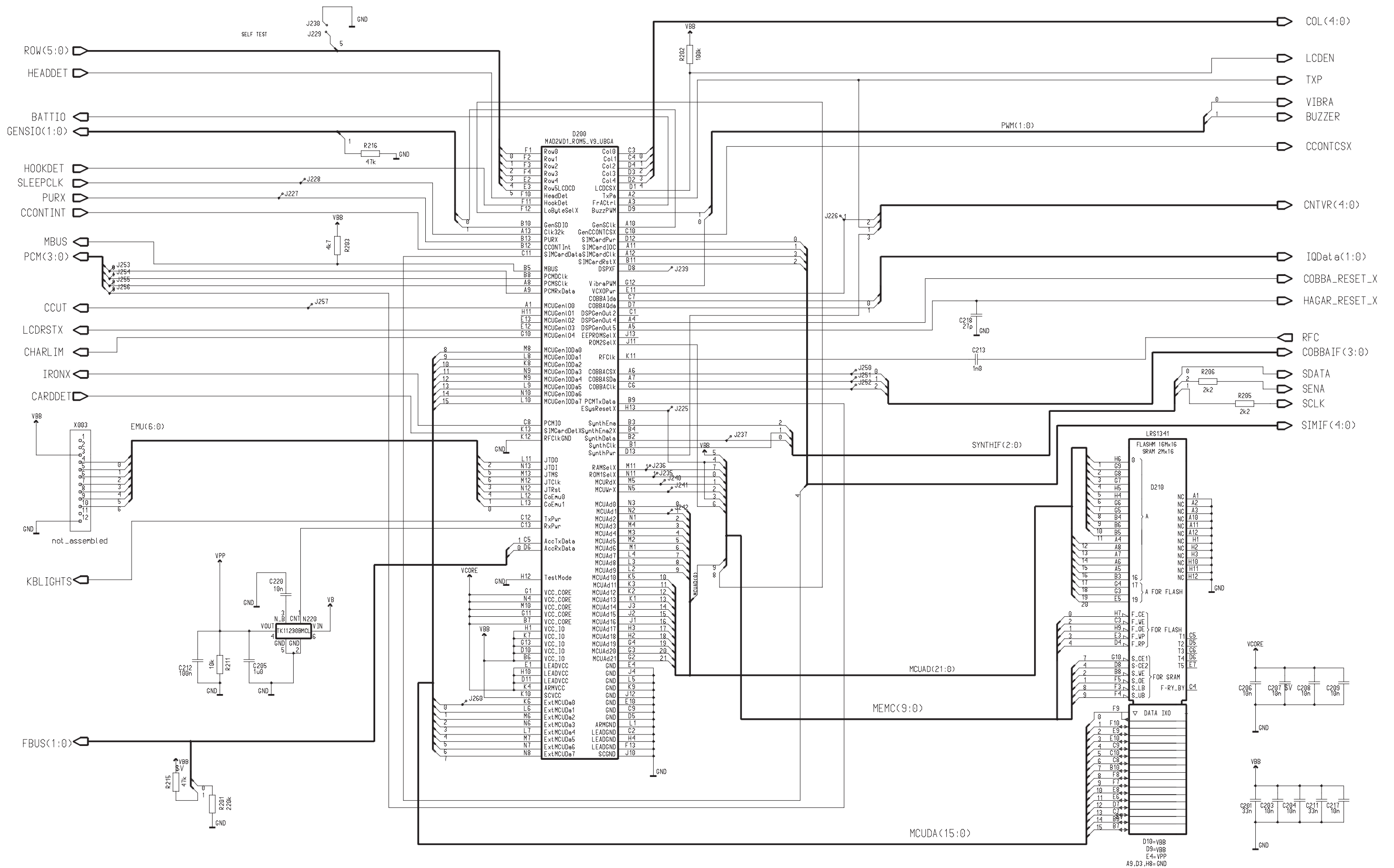



**Circuit Diagram of Audio and RFI** (Version 0391 Edit 2) for layout version 14

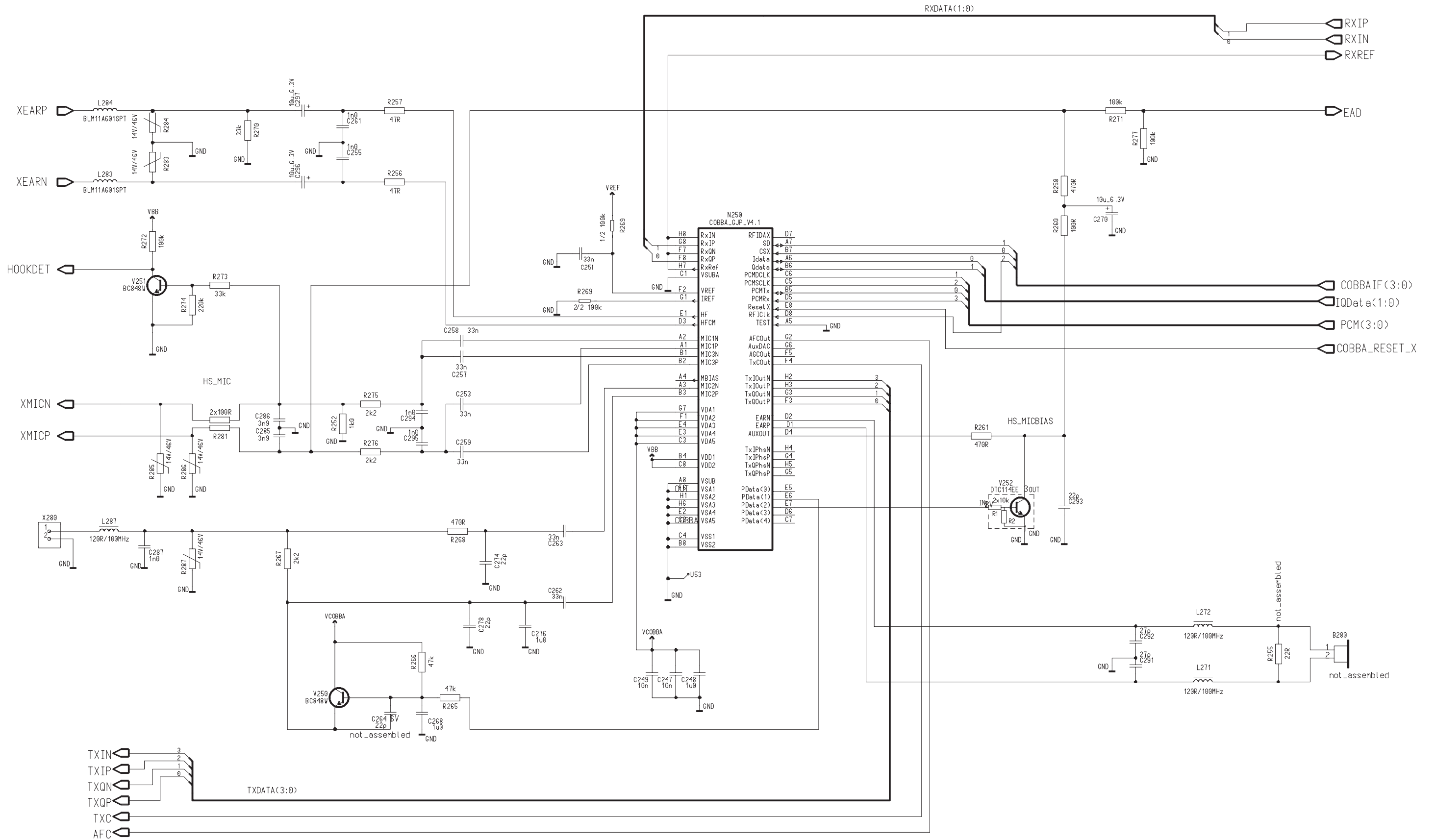

Circuit Diagram of IR Module (Version 0391 Edit 2) for layout version 14

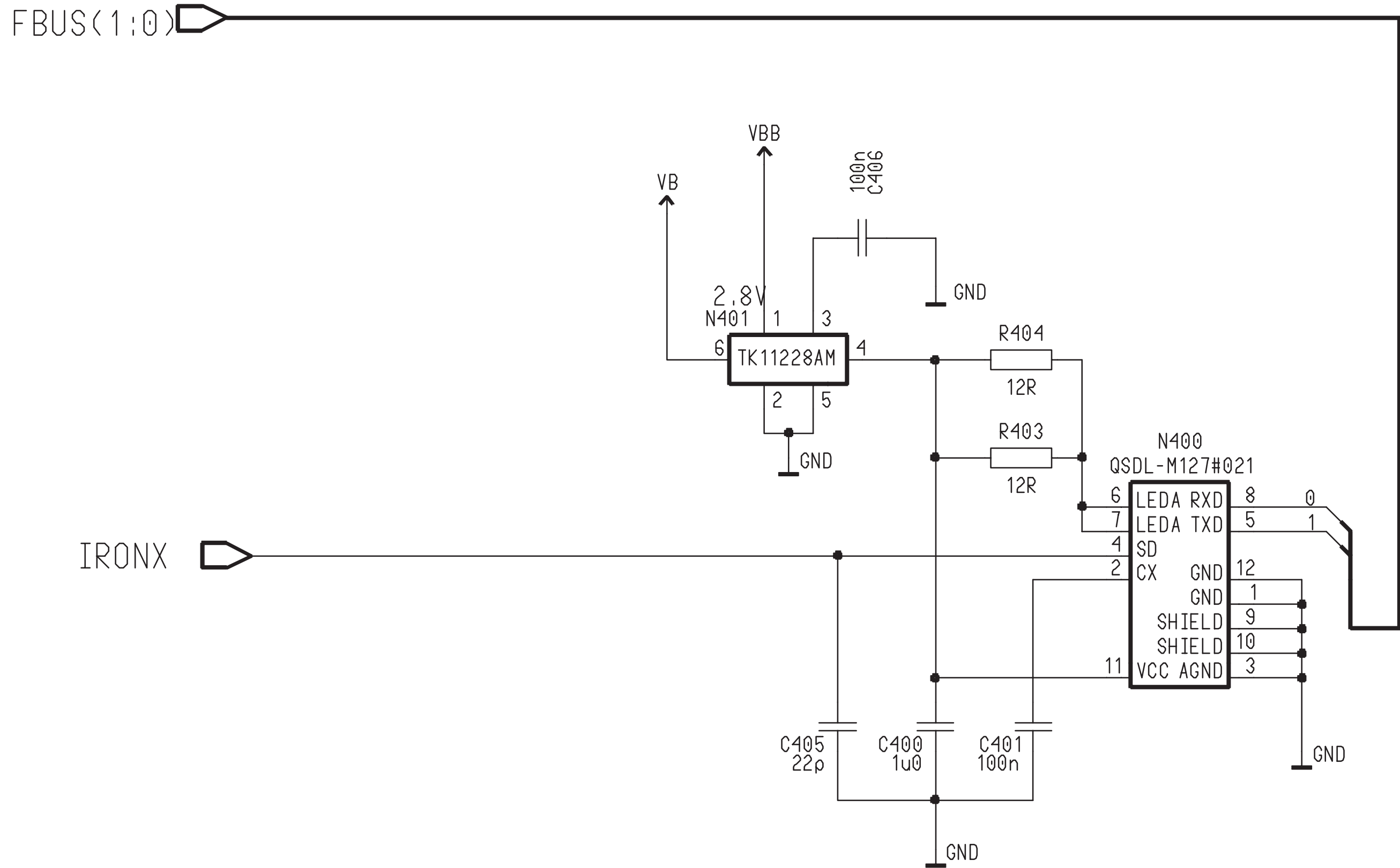

**Circuit Diagram of UIF** (Version 0391 Edit 2) for layout version 14

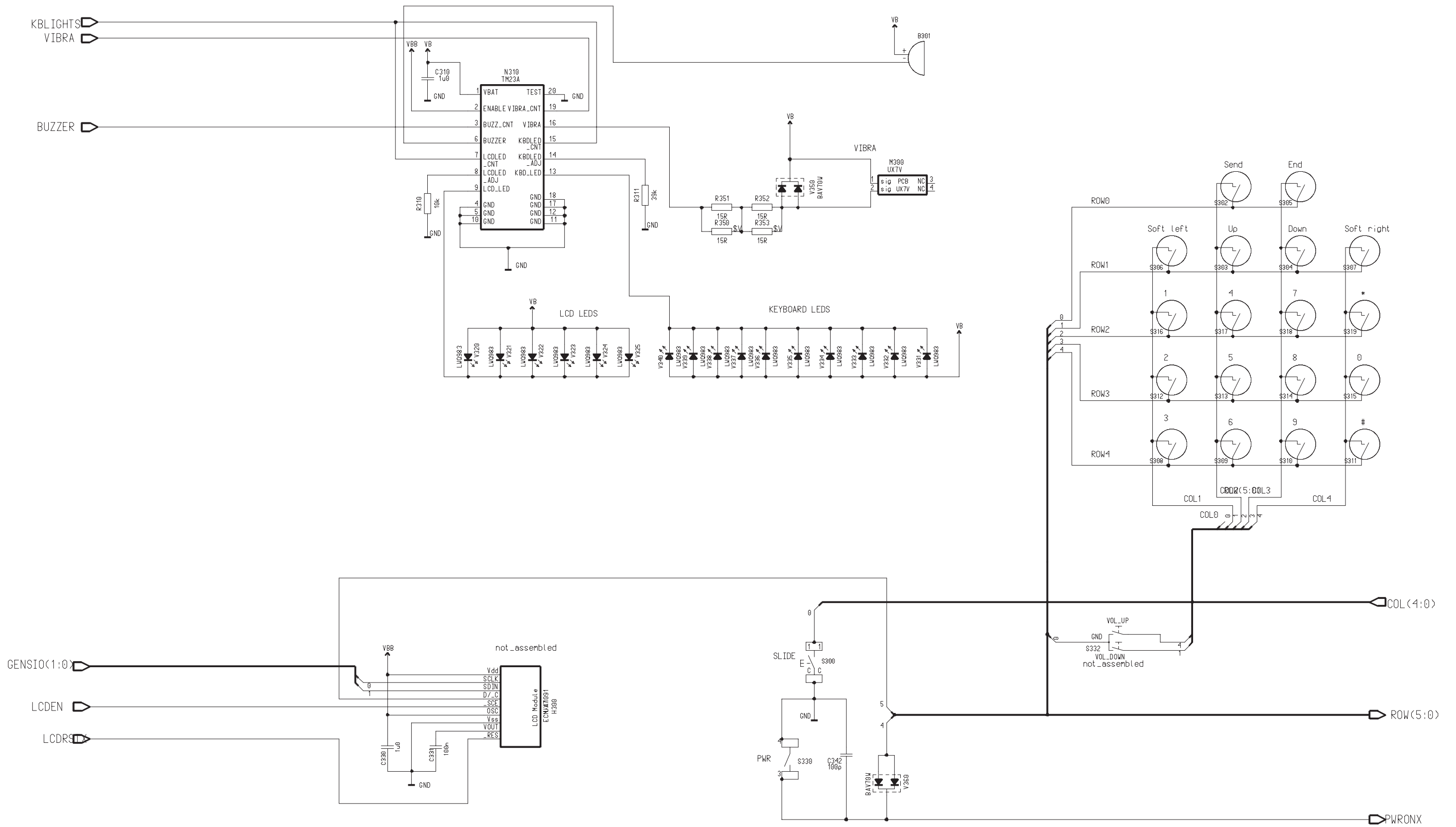





Testpoints of RM7 – Top (Version 14)

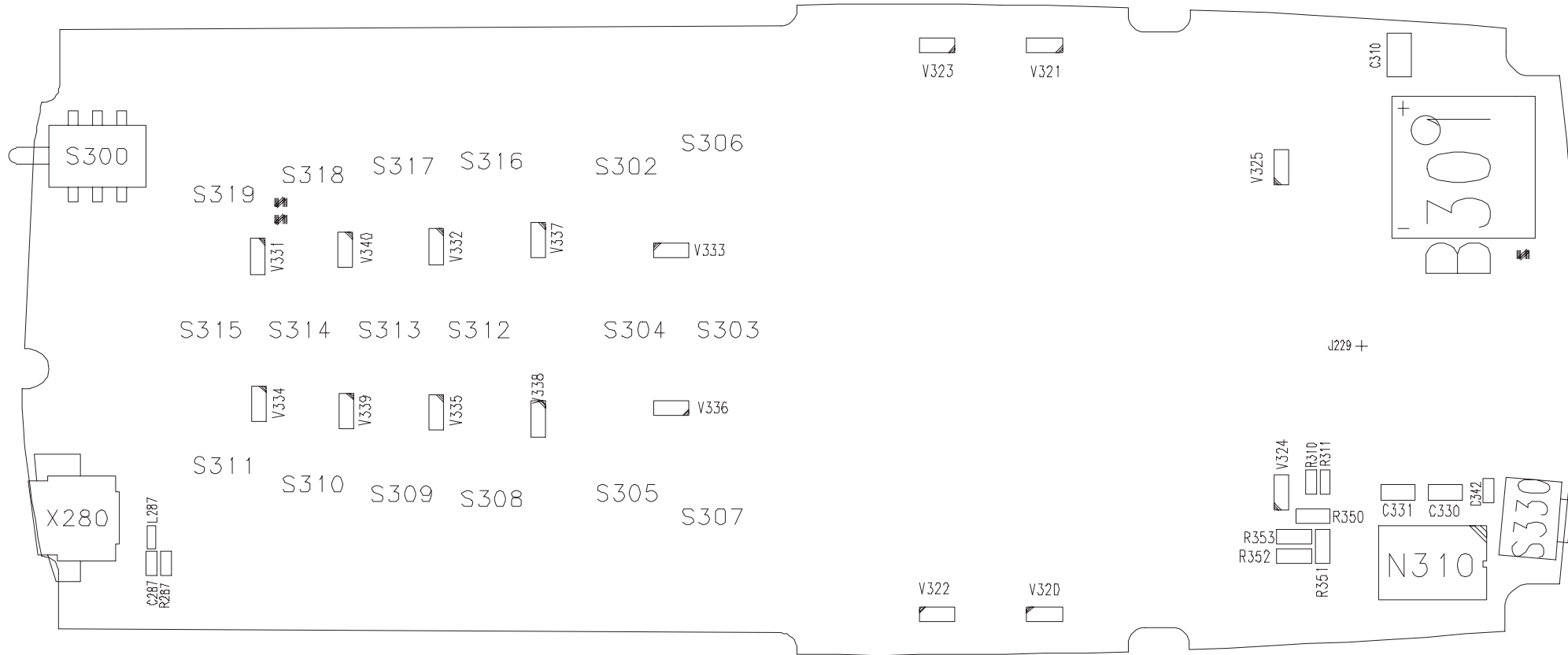

Testpoints of RM7 – Bottom (Version 14)

